

ICE BUILDER

PIB 25 - 160

Application

Ice water has been used for many years in (large) dairy farms and in collection centres because it can cool large amounts of milk in a very short time. A **lot of ice** can be stored on a small area, which results in a compact space saving unit. Thanks to this **large ice reserve**, a huge amount of **ice water at zero degrees** can be produced. In combination with robotic milking there is **no risk of freezing** even for the smallest quantities of milk.

The CFC-free polyurethane assures a perfect insulation, without any cold bridges



Construction

- Construction completely made in stainless steel 18/10 – AISI 304
- Insulated with polyurethane foam for an excellent insulation and extra strength of the tank
- The well dimensioned evaporator enables the storage of a large ice reserve, this guarantees a maximum cold transfer
- The evaporator is made of seamless copper tubes and mounted in a stainless steel frame for a long lifetime

Operation

- Accumulation of energy at cheaper electricity rates via e.g. night rate or alternative energy such as solar panels
- An ice thickness probe activates the Eco-cool cooling unit until an equal layer of ice on all evaporator tubes has been built
- The water in the ice builder is cooled to 0.5°C.
- By means of one or more ice water pumps the ice water is sent to the milk cooling tank or a pre-cooler to cool down the milk
- The ice is melted down by the warm water returning from the consumer
- One high pressure air blower pushes compressed air through a PVC-collector on the bottom of the ice builder. This air causes sufficient turbulence in the water so the ice melts evenly, which guarantees a water temperature of 0.5 °C

Important options

- Supplementary ice water pump, e.g. for instant cooling
- Anti-frost protection
- Other type of ice water pump
- Time clock for use of night rate - only if not in combination with a milk cooling tank with iControl

DIMENSIONS

PIB 25 - 160

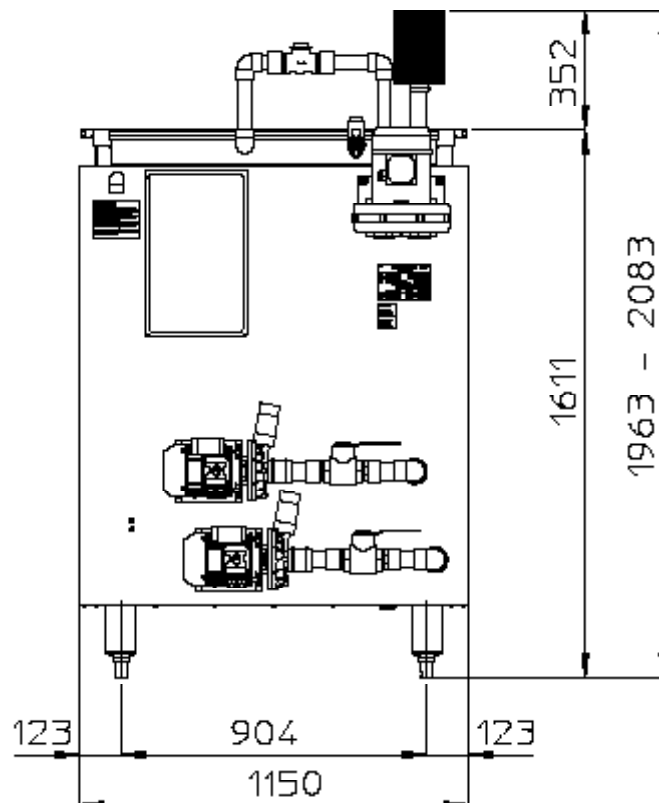
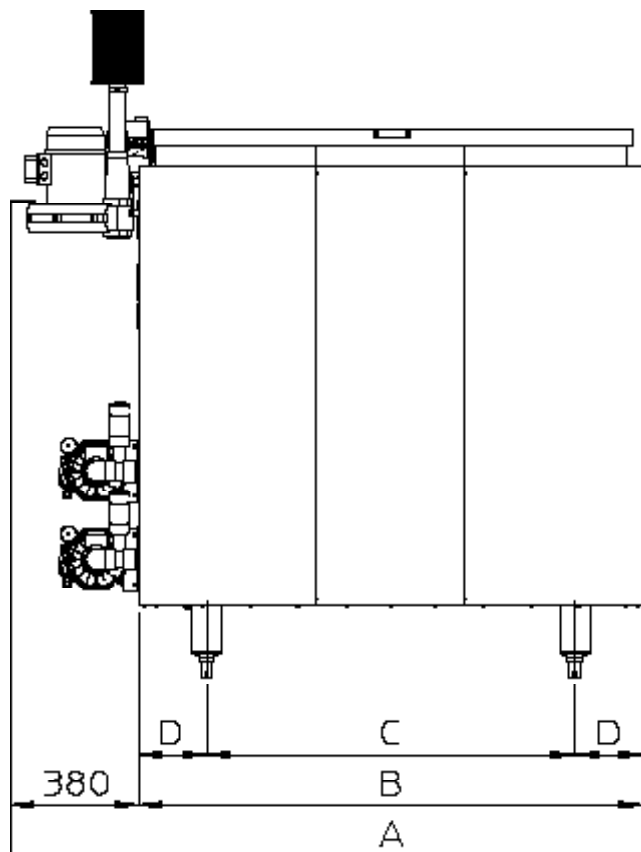

Model	Energy storage		Amount of ice kg	Amount of water litres	A mm	B mm	C mm	D mm	# Legs	Weight kg
	kWh	kcal								
25	25.8	22160	277	1154	1432	1052	648	202	4	320
40	41.2	35456	443	1154	1432	1052	648	202	4	370
60	61.8	53184	665	1692	1872	1492	1088	202	4	437
80	82.5	70912	886	2229	2312	1932	1528	202	4	532
120	123.7	106368	1330	3304	3192	2812	2408	202	6	690
160	164.9	141824	1773	4379	4072	3692	3288	202	6	840

Fullwood Packo nv

Torhoutsesteenweg 154 - 8210 Zedelgem - Belgium

T +32 50 25 06 10 - E cooling@fullwoodpacko.com

www.packocooling.com